

# SR 400

**OUTDOOR SIREN  
SIRENE EXTERIOR  
SIRÈNE EXTÉRIEURE**

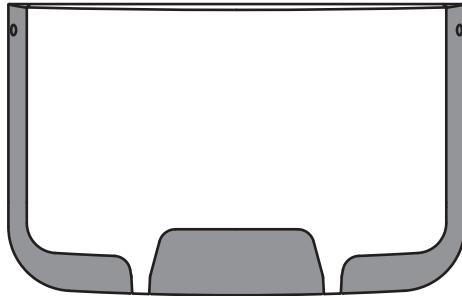

**Installation Manual  
Manual de instalação  
Manuel d'installation**



## **GUARANTEE**

During the guarantee period the manufacturer shall, at its sole discretion, replace or repair any defective product when it is returned to the factory. All parts replaced and/or repaired shall be covered for the remainder of the original guarantee, or for ninety (90) days, whichever period is longer. The original purchaser shall immediately send manufacturer a written notice of the defective parts or workmanship, which written notice must in all cases be received prior to expiry of the guarantee.

### **International Guarantee**

Foreign customers shall enjoy the same guarantee rights as those enjoyed by any customer in Bulgaria, except that manufacturer shall not be liable for any related customs duties, taxes or VAT, which may be payable.

### **Guarantee Procedure**

This guarantee will be granted when the appliance in question is returned. The manufacturer shall accept no product whatsoever, of which no prior notice has been received.

### **Conditions for waiving the guarantee**

This guarantee shall apply to defects in products resulting only from improper materials or workmanship, related to its normal use. It shall not cover:

- § Damages resulting from transportation and handling;
- § Damages caused by natural calamities, such as fire, floods, storms, earthquakes or lightning;
- § Damages caused by incorrect voltage, accidental breakage or water; beyond the control of the manufacturer;
- § Damages caused by unauthorized system incorporation, changes, modifications or surrounding objects;
- § Damages caused by peripheral appliances (unless such peripheral appliances have been supplied by the manufacturer);
- § Defects caused by inappropriate surrounding of installed products;
- § Damages caused by failure to use the product for its normal purpose; Damages caused by improper maintenance;
- § Damages resulting from any other cause, bad maintenance or product misuse.

In the case of a reasonable number of unsuccessful attempts to repair the product, covered by this guarantee, the manufacturer's liability shall be limited to the replacement of the product as the sole compensation for breach of the guarantee. Under no circumstances shall the manufacturer be liable for any special, accidental or consequential damages, on the grounds of breach of guarantee, breach of agreement, negligence, or any other legal notion.

### **WAIVER**

This Guarantee shall contain the entire guarantee and shall be prevailing over any and all other guarantees, explicit or implicit (including any implicit guarantees on behalf of the dealer, or adaptability to specific purposes), and over any other responsibilities or liabilities on behalf of the manufacturer.

The manufacturer does neither agree, nor empower, any person, acting on his own behalf, to modify or alter this Guarantee, nor to replace it with another guarantee, or another liability with regard to this product.

### **Unwarranted Services**

The manufacturer shall repair or replace unwarranted products, which have been returned to its factory, at its sole discretion under the conditions below. The manufacturer shall accept no products for which no prior notice has been received.

The products, which the manufacturer deems repairable, will be repaired and returned. The manufacturer has prepared a price list and those products, which can be repaired, shall be paid for every repaired appliance.

The closest equivalent product, available at the time, shall replace the products manufacturer deems un-repairable. The current market price shall be charged for every replaced product.

## **GARANTIA**

Durante a garantia o fabricante deve, a seu exclusivo critério, repor ou reparar qualquer produto defeituoso, quando este é devolvido para fábrica. Todas as partes substituídas e/ou reparadas devem ser cobertas até ao final da garantia original, ou por noventa (90) dias, conforme o período que for mais longo. O comprador de origem deve imediatamente enviar para o fabricante uma notificação por escrito das partes e/ou mão de obra defeituosa, mais longo. O comprador de origem deve imediatamente enviar para o fabricante uma notificação por escrito das partes e/ou mão de obra defeituosa.

### **GARANTIA INTERNACIONAL**

Os clientes estrangeiros devem desfrutar dos mesmos direitos de garantia que qualquer cliente na Bulgária, há excepção de que o fabricante não pode ser responsabilizado por direitos alfandegários, taxas ou VAT, que podem ser pagas.

### **PROCEDIMENTOS DE GARANTIA**

Esta garantia será concedida quando o equipamento em questão é devolvido. O fabricante não deve aceitar qualquer produto, ao qual não tenha recebido aviso prévio.

### **CONDIÇÕES PARA RENÚNCIA DE GARANTIA**

A garantia deve ser aplicada a produtos defeituosos resultantes apenas de materiais impróprios ou mão de obra inadequada, relacionadas com a sua utilização normal. A garantia deve cobrir:

- § Danos resultantes do transporte e manuseamento;
- § Danos causados por calamidades naturais, como incêndio, inundações, tempestades, sismos ou relâmpagos;
- § Danos causados pela incorporação em sistemas não autorizados, alterações, modificações ou objectos circundantes;
- § Danos causados por aparelhos periféricos (a menos que estes periféricos tenham sido fornecidos pelo fabricante);
- § Defeitos causados pelo ambiente inadequado de produtos instalados;
- § Defeitos causados por falta de usar o produto para a sua normal finalidade;
- § Danos causados por manutenção imprópria;
- § Danos causados por qualquer outra causa, má manutenção ou má utilização.

No caso de um razoável número de tentativas sem sucesso na reparação do produto, coberto por esta garantia, a responsabilidade do fabricante será limitada à reposição do produto, como única compensação por violação da garantia. Sob nenhuma circunstância o fabricante deve ser responsabilizado por acidentes ou danos consequentes do mesmo, em razão da violação da garantia, violação do acordo, negligência ou qualquer outra notificação legal.

### **RENÚNCIA**

Esta garantia deve conter a todos elementos de garantia e deve prevalecer sobre outras garantias, explícitas ou não explícitas (incluindo qualquer garantia não explícita em nome do revendedor, ou adaptabilidade de propósitos específicos), e acima de quaisquer outras responsabilidades em nome do fabricante. O fabricante não tem de concordar nem autorizar, qualquer pessoa, agindo em seu próprio nome, para modificar ou alterar esta garantia, não para a substituir com outra garantia, ou de outra responsabilidade em relação a este produto.

### **SERVIÇOS SEM GARANTIA**

O fabricante deve reparar e repor produtos sem garantia, que tenham sido devolvidos para a fábrica, a seu exclusivo critério nas condições abaixo: O fabricante não deve aceitar produtos aos quais não tenha recebido nenhuma notificação prévia. O produtos, aos quais o fabricante considere reparáveis, serão reparados e enviados de volta.

O fabricante tem elaborado uma lista de preços e produtos, que é aplicado de acordo com a reparação.

Em caso do produto não ser reparável, e não existir disponível de momento, o fabricante deve efectuar a troca por um produto equivalente.

O preço actual do mercado deve ser cobrado por cada produto substituído.

#### **GARANTIE**

Durant la période de garantie, le fabricant se doit de remplacer ou réparer tout produit defectueux lorsqu'il est renvoyé à l'usine. Toutes les pièces remplacées ou réparées seront sous garantie, soit sous la garantie originale, soit sous 90 jours selon la période la plus longue. L'acheteur devra immédiatement envoyer une fiche SAV aux techniciens, sur lequel sera indiqué les pièces défectueuses ou les défauts de fabrications. Ce document devra dans tout les cas être envoyé avant l'expiration de la garantie.

#### **Garantie internationale**

Les clients étrangers bénéficient des mêmes droits que les clients Bulgares, excepté que les fabricants ne sont pas responsables des droits de douanes, taxes ou TVA, qui pourraient être à la charge des clients.

#### **Procédure de garantie**

Cette garantie sera accordée dès lors que le produit sera retourné. Le fabricant ne pourra accepter aucun produit sans fiche SAV.

#### **Conditions**

Cette garantie n'est applicable que sur des défauts de matériaux ou de fabrications durant une utilisation normale. Il ne couvre pas :

- Les dommages résultant d'un mauvais transport ou de mauvaises manipulations
  - Les dommages causés par des catastrophes naturelles, comme les incendies, les inondations, les tempêtes, les tremblements de terre ou la foudre
  - Les dommages causés par une tension incorrecte, une casse accidentelle ou d'eau
  - Les dommages causés par l'incorporation non autorisée au système de changements, modifications ou objets divers
  - Les dommages causés par des appareils périphériques autres que ceux fournis par le fabricant
  - Les dommages causés par l'installation de produit inapproprié.
  - Les dommages causés par le fait de ne pas utiliser le produit selon son usage normale
  - Les dommages causés par un mauvais entretien
  - Les dommages résultant de tout autre cause: mauvais entretien, ou mauvais utilisation du produit
- Dans le cas de tentatives infructueuses pour réparer le produit, sous garantie, la responsabilité du fabricant se limite, comme unique rupture de garantie, au remplacement du produit. En aucun cas le fabricant ne sera tenu responsable des dommages spéciaux, accidentels ou consécutifs sur les motifs de violation de garantie, d'accord, ou de négligence ou toute autre notion juridique.

#### **Renonciation**

Cette garantie doit contenir la totalité de la garantie et prévaut sur toute autre garantie, implicites ou explicites, et sur toutes autres responsabilités ou obligations au nom du fabricant.

Le fabricant ne peut ni donner son accord ni autoriser qui que ce soit à agir en son nom dans le but de modifier ou remplacer cette garantie par une autre.

#### **Services sans garantie**

Le fabricant doit réparer ou remplacer les produits sans garantie qui ont été renvoyés à l'usine, sous les conditions ci-dessous. Le fabricant ne peut accepter de produit sans fiche SAV justifiant les soucis techniques.

Les produits qui semblent être réparables par le fabricant seront réparés et renvoyés. Le fabricant a préparé une liste de prix et les produits réparables devront être facturés. Le produit le plus similaire pourra remplacer le produit défectueux dès lors que le fabricant le juge irréparable.

## **SR 400 Outdoor Piezo Siren**

EN 50131-1:2006/A1:2009/A2:2017/A3:2020

EN 50131-4:2019

**Grade 3 Class IV**



Cert. No: TT-494/2021

# LED Indication / Indicação do LED / LED d'indication

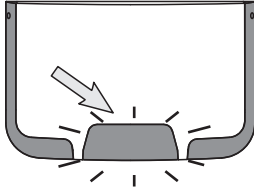

Blue color / Cor azul / Couleur bleue

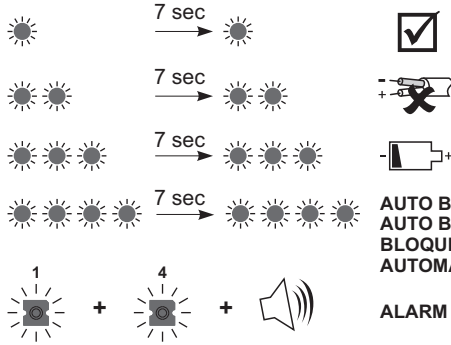
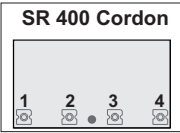
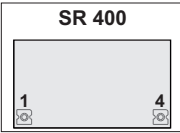

AUTO BLOCKED /  
AUTO BLOQUEIO /  
BLOQUEE  
AUTOMATIQUEMENT

ALARM / ALARME

Cordon - 4 Chaser LEDs / Chenillard 4 LED

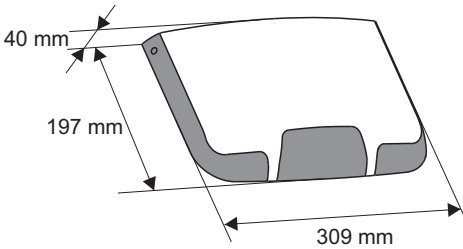
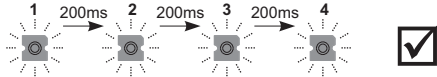

0.78 kg  
(with battery / com bateria /  
avec la batterie)



9V / 1100mAh

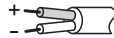

13.8 V - 14.2 V DC



18mA



270mA



**Low / Baixo / Min:** 85dB / 1m

**Hi / Alto / Max:** 105dB / 1m



**10**



2,8 - 3,1 KHz



-30°C - +70°C

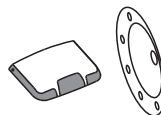

IK08  
IP45

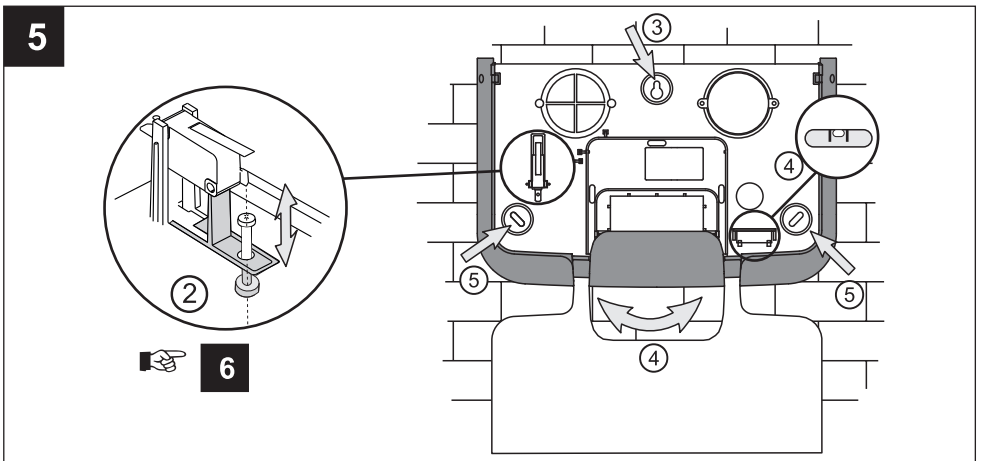
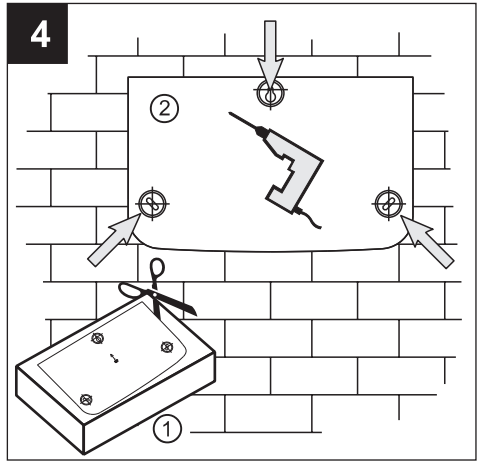
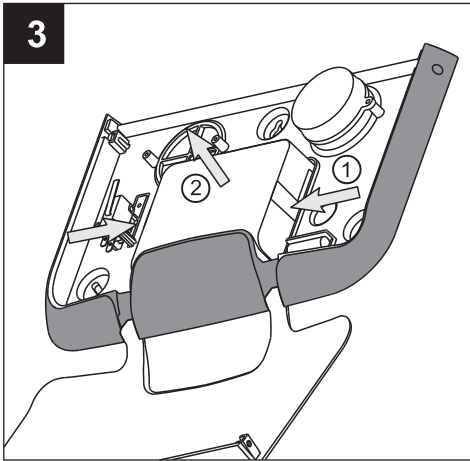
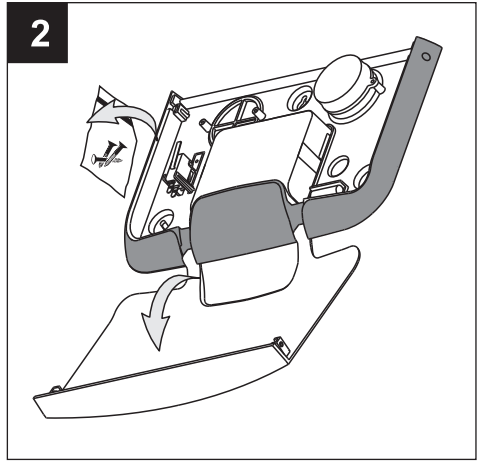
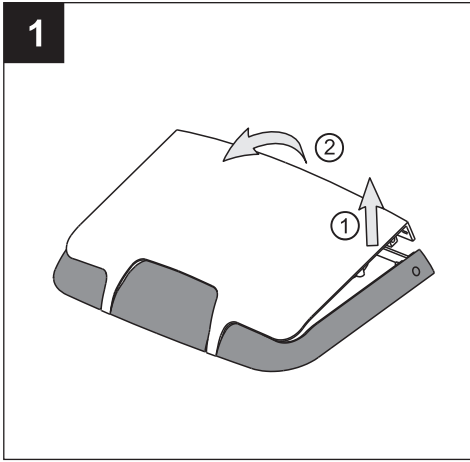

## 6 TAMPER Adjustment / Ajuste do TAMPER / Réglage du contact d'autoprotection

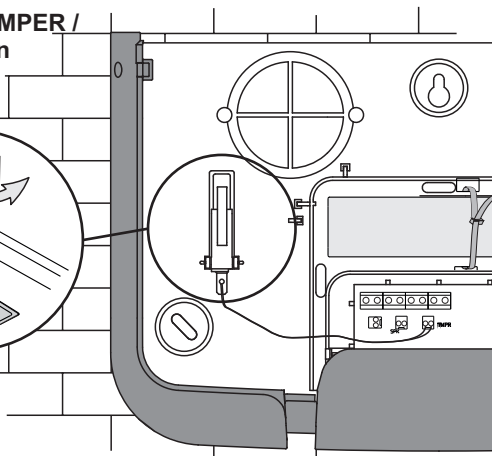
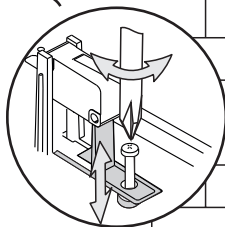
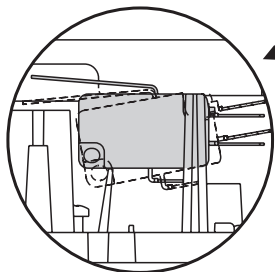

7

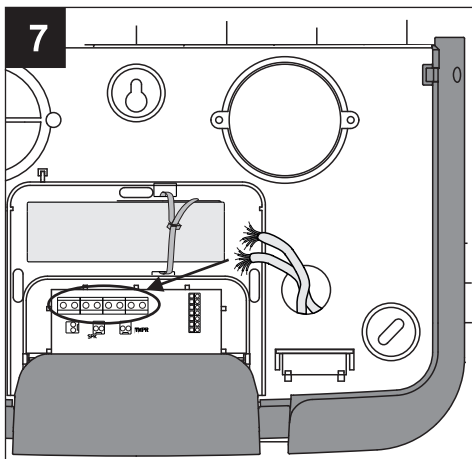

8

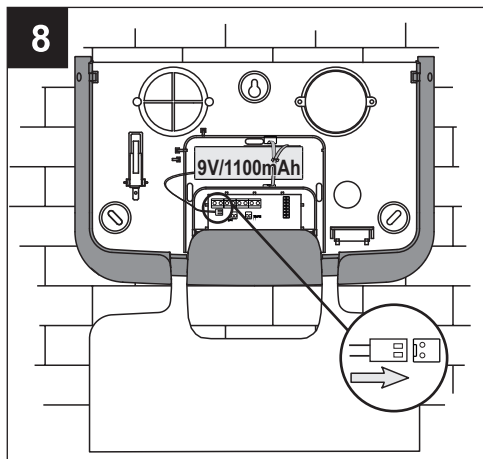

## 9 Terminals / Terminais / Bornes

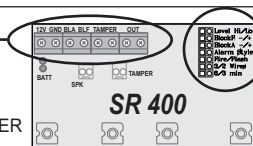

## Jumpers / Cavaliers

See on the next page /  
Veja na página 8  
Voir page suivante 9

- **TAMPER** - TAMPER signal/ Sinal de TAMPER/ Signal de TAMPER
- **12V** - Power supply 12V/ Alimentação 12V/ Alimentation 12V
- **GND** - Grounding/ Negativo/ Masse 0V
- **BLA** - Input, Block Alarm signal/ Disparo de alarme por remoção +/- / Tension de blocage Signal alarme intrusion par +/-
- **BLF** - Input, Block Fire alarm signal/ Disparo de Fogo por remoção +/- / Tension de blocage Signal alarme incendie +/-
- **OUT** - Output, NC contact - activated in case of "Technical Trouble" condition (with LED indication - see page 4)  
Saída, NC contact - activada no caso de problemas técnicos (junto com indicação por LED - ver pág. 4) /  
Sortie, NC contact - activé en cas de problème techniques (LED d'indication - voir page 4)

The possible "Technical Trouble" condition are/ Possíveis problemas técnicos/

Les conditions de problème techniques possibles sont:

- "Power lost" - no power supply from the panel/ "Perda alimentação" - falta de alimentação 12V\*\*/ "Pertes d'alimentation"
- "Battery lost" - low charge of the battery, missing battery/ "Bateria baixa" - bateria com pouca carga\*\*/ "Perte de batterie"
- "Auto Blocked" - the auto blocking system is activated/ "Auto-Bloqueio" - o sistema de auto-bloqueio é activado\*\*/ "Blocage automatique"

\*The trouble indication will stop, when the block signal is restored and the siren in back in Normal operation mode.

\*\* A indicação de problema irá parar, quando o sinal de bloqueio terminar e a sirene entrar em modo de operação normal.

# 10 Connection diagrams

## 3 - wire connection

Jumper **BlockA** is set.

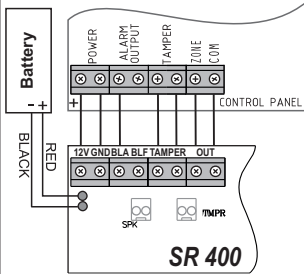



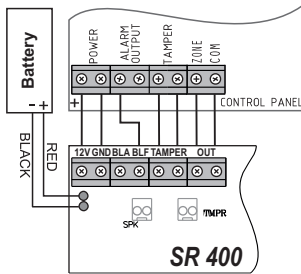

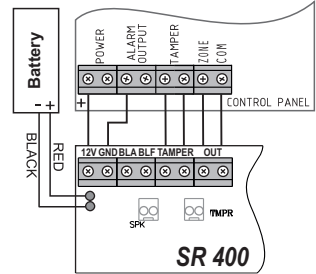

Jumper **BlockF** is set.



## 2 - wire connection



Jumper	3 - wire connection		2 - wire connection	
	The jumper is removed. 	The jumper is set. 	The jumper is removed. 	The jumper is set. 
<b>Level Hi/Lo</b>	High level 105dB / 1m	Low level 85dB / 1m	High level 105dB / 1m	Low level 85dB / 1m
<b>BlockA -/+*</b> (see page 10)	Alarm blocking at <b>low</b> level of <b>BlockA</b> signal.	Alarm blocking at <b>high</b> level of <b>BlockA</b> signal.	-	-
<b>BlockF -/+**</b> (depends on the setting for Fire/Flash jumper, see also page 10)	<b>Fire / Flash Removed:</b> Blocking of <b>Fire</b> at <b>low</b> level of <b>BlockF</b> signal.	<b>Fire / Flash Removed:</b> Blocking of <b>Fire</b> at <b>high</b> level of <b>BlockF</b> signal.	-	-
	<b>Fire / Flash Set:</b> Blocking of <b>Flash</b> at <b>low</b> level of <b>BlockF</b> signal. (At alarm signal - flash only, no sound indication)	<b>Fire / Flash Set:</b> Blocking of <b>Flash</b> at <b>high</b> level of <b>BlockF</b> signal. (At alarm signal - flash only, no sound indication)		
<b>Alarm Style</b>	Low level sound - 1,78Hz.	High level sound - 3,56Hz.	Low level sound - 1,78Hz.	High level sound - 3,56Hz.
<b>Fire / Flash</b>	With no <b>BlockF</b> signal - <b>Fire</b> signal with low level sound 1,78Hz.	With no <b>BlockF</b> signal - <b>Flash</b> is blinking in time with the sound; With <b>BlockF</b> signal - the <b>Flash</b> does not blinking at alarm signal.	Working with the battery - the alarm system will not be activated if switching on the siren without power supply.	Working without the battery - the alarm system will be activated if switching on the siren without power supply.
<b>3/2 wires</b>	The jumper is removed. 		The jumper is set. 	
<b>6/3 min</b>	Auto-blocking at alarm signal after <b>6 min.</b>	Auto-blocking at alarm signal after <b>3 min.</b>	Auto-blocking at alarm signal after <b>6 min.</b>	Auto-blocking at alarm signal after <b>3 min.</b>





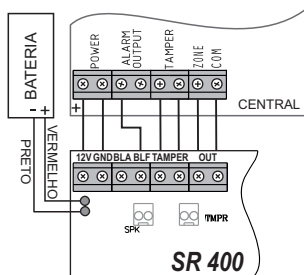
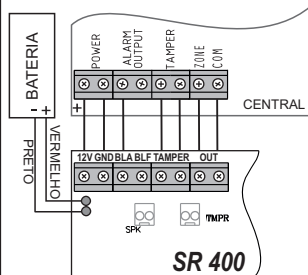

# 10 DIAGRAMAS DE LIGAÇÃO

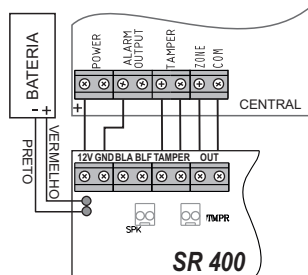
## Ligação com 3 fios



## Ligação com 2 fios



Jumper	Ligação com 3 fios		Ligação com 2 fios	
	O jumper removido 	O jumper aplicado 	O jumper removido 	O jumper aplicado 
<b>Level Hi/Lo</b>	Nível alto 105 dB/1m	Nível baixo 85 dB/1m	Nível alto 105 dB/1m	Nível baixo 85 dB/1m
<b>BlockA -/+*</b>	Disparo do alarme por remoção do negativo (-)	Disparo do alarme por remoção do positivo (+)	-	-
<b>BlockF -/+**</b>	Disparo do alarme por remoção do negativo (-)  Com o jumper <b>Fire/Flash</b> removido: activa o flash e o som Com o jumper <b>Fire/Flash</b> aplicado: activa o flash e sem som	Disparo do alarme por remoção do positivo (+)  Com o jumper <b>Fire/Flash</b> removido: activa o flash e o som Com o jumper <b>Fire/Flash</b> aplicado: activa o flash e sem som	-	-
<b>Alarm Style</b>	Nível de som Baixo: 1,78 Hz	Nível de som Alto: 3,56 Hz	Nível de som Baixo: 1,78 Hz	Nível de som Alto: 3,56 Hz
<b>Fire / Flash</b>	Disparo do alarme por remoção do negativo (-) Baixo nível de som	Disparo do alarme por remoção do positivo (+) Com o jumper aplicado no BlockF não tem som, só flash	Com a bateria ligada, o disparo é feito pela remoção da alimentação	Sem a bateria ligada, o disparo é feito pela aplicação da alimentação
<b>3 / 2 Wires</b>	O jumper removido 3 fios 		O jumper aplicado 2 fios 	
<b>6/3 min</b>	Tempo máximo do alarme: 6 min.	Tempo máximo do alarme: 3 min	Tempo máximo do alarme: 6 min	Tempo máximo do alarme: 3 min







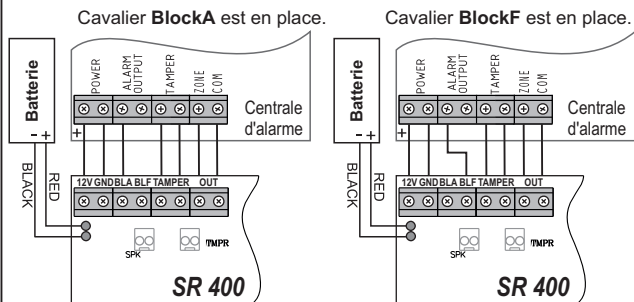

# 10 Schéma de connexion

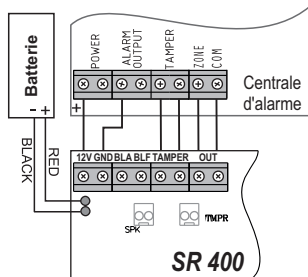
## Connexion 3 fils



## Connexion 2 fils



Cavalier	3 fils		2 fils	
	Le cavalier est retiré 	Le cavalier est positionné 	Le cavalier est retiré 	Le cavalier est positionné 
<b>Level Hi/Lo</b>	Haut niveau 105dB / 1m	Bas niveau 85dB / 1m	Haut niveau 105dB / 1m	Bas niveau 85dB / 1m
<b>BlockA -/+*</b> (page 10)	Blocage Sirène par une entrée négative (-0V) sur <b>BlockA</b> .	Blocage Sirène par une entrée positive (+12V) sur <b>BlockA</b> .	-	-
<b>BlockF -/+**</b> (dépend du réglage de cavalier Fire / Flash, voir aussi page 10)	<b>Flash / incendie Retiré:</b> Blocage Sirène par une entrée négative (-0V) sur <b>BlockF</b> .	<b>Flash / incendie Retiré:</b> Blocage Sirène par une entrée positive (+12V) sur <b>BlockF</b> .	-	-
	<b>Feu / Flash Set:</b> Blocage Sirène par une entrée négative (-0V) sur <b>BlockF</b> (en alarme, pas de signalisation sonore).	<b>Feu / Flash Set:</b> Bloqué sur Flash à haut niveau sur Signal <b>BlockF</b> (en alarme, pas de signalisation sonore).		
<b>Alarm Style</b>	Niveau faible - 1,78Hz.	Niveau élevé - 3,56Hz.	Niveau faible - 1,78Hz.	Niveau élevé - 3,56Hz.
<b>Fire / Flash</b>	Sans Signal sur <b>BlockF</b> – Signal incendie avec tonalité à 1,78Hz et signalisation avec flash.	Sans signal sur <b>BlockF</b> – Flash clignote lentement Avec le cavalier <b>Type de tonalité</b> – le flash clignote raoidement en cas d'alarme.	Travail avec la batterie – le système d'alarme ne sera pas activé si l'on switch sur la sirène sans alimentation.	Travail avec la batterie – le système d'alarme sera activé si l'on switch sur la sirène sans alimentation.
<b>3/2 wires</b>	Le cavalier est retiré. 		Le cavalier est positionné. 	
<b>6/3 min</b>	Auto-blocage après 6min du signal d'alarme.	Auto-blocage après 3min du signal d'alarme.	Auto-blocage après 6min du signal d'alarme.	Auto-blocage après 3min du signal d'alarme.

**\*BlockA -/+ Jumper** - In case of connecting SR 400 to a burglary zone of the alarm control panel. The function of the jumper is to specify the level of the **Alarm blocking signal**: Low level (GND) or High level (+12V).

**\*\*BlockF -/+ Jumper** - In case of connecting SR 400 to a fire zone (or PGM output) of the alarm control panel. The function of the jumper is to specify the level of the **Fire blocking signal**: Low level (GND) or High level (+12V).

The functionality of *BlockF* -/+ jumper depends on the settings for *Fire/Flash* jumper. For example: With *BlockF* -/+ jumper removed and *Fire/Flash* jumper set in case of fire alarm signal there will be no sound, and only flash indication. This setting is suitable when the installer wants to test the proper work of the fire detectors in the system but without sound. The other combinations are given in the table on page 7. The *BlockA* -/+ and *BlockF* -/+ jumpers can be set at the same time together. In this situation if a burglary and fire alarm signals come simultaneously the fire signal will be with priority and SR 400 will sound as a fire siren.

**\*BlockA -/+ Jumper** - no caso da ligação da SR 400 a uma central de intrusão. A função do jumper é definir se o disparo é por remoção de negativo ou positivo.

- Nível baixo - GND (jumper removido)
- Nível alto - + 12V (jumper aplicado)

**\*\*BlockF -/+ Jumper** - no caso da ligação da SR 400 a uma central de incêndio (ou saída PGM). A função do jumper é definir se o disparo de incêndio é por remoção de negativo ou positivo.

- Nível baixo - GND (jumper removido)
- Nível alto - + 12V (jumper aplicado)

A funcionalidade do jumper *BlockF* -/+ depende do jumper *Fire/Flash*. Exemplo: Com o jumper *BlockF* -/+ removido e o jumper *Fire/Flash* aplicado no caso de alarme não haverá som, só flash. Esta definição é adequada quando o instalador quer testar o bom trabalho dos detectores no sistema porém sem som. As restantes combinações são dadas na tabela anterior (veja na página 8).

Os jumpers *BlockA* -/+ e *BlockF* -/+ podem ser definidos ao mesmo tempo. Nesta situação no caso de um disparo de intrusão ou incêndio ao mesmo tempo, a prioridade é do sistema de incêndio, a SR 400 tocará como uma sirene de incêndio.

**\*Cavalier BlockA -/+** – en cas de connexion de la SR 400 à une sortie sirène (ou PGM) sur la centrale d'alarme. La fonctionnalité du cavalier est de spécifier la polarité du signal de blocage d'alarme: Négatif (GND) ou positif (+12V).

**\*\* Cavalier BlockF -/+** – en cas de connexion de la SR 400 à une zone d'incendie (ou sortie PGM) sur la centrale d'alarme. La fonctionnalité du cavalier est de spécifier la polarité du signal de déclenchement incendies: Négatif (GND) ou positif (+12V).

La fonctionnalité du cavalier *BlockF* -/+ dépend des paramètres du cavalier *Feu/Flash*. Par exemple: avec le cavalier *BlockF* +/- déconnecté et le cavalier *Feu/Flash* branché, en cas d'alarme incendie il n'y aura pas de son, seulement une indication qui clignote. Ce paramétrage convient lorsque l'installateur veut tester le travail des détecteurs d'incendie dans le système mais sans son. Les autres combinaisons sont indiquées dans le tableau page 9.

Les cavaliers *BlockA* -/+ et *BlockF* -/+ peuvent être connectés ensemble au même moment. Dans cette situation si un signal de intrusion et d'alarme incendie arrivent ensemble, l'alarme incendie sera prioritaire et SR 400 retentira comme une sirène d'incendie.

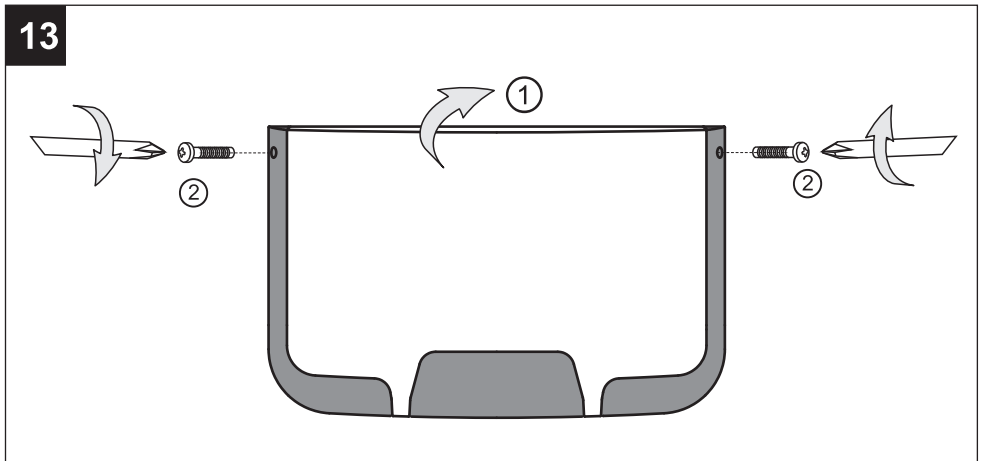
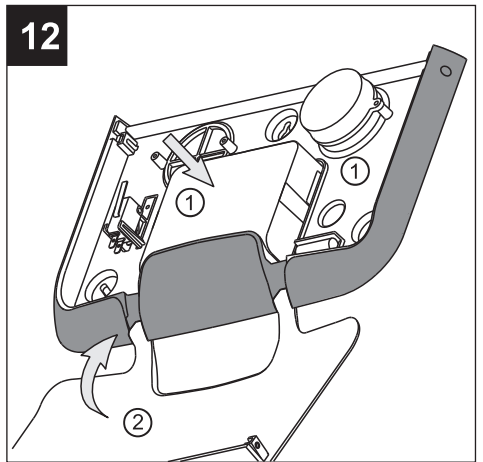
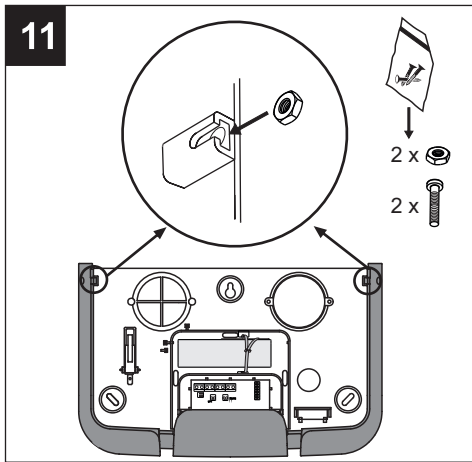

The information in this manual is a subject to change without notice.  
Este manual está sujeito a alteração sem aviso prévio!  
Ce manuel peut être modifié sans préavis!

**Teletek Electronics JSC**  
Address: 14A Srebarna Str, 1407 Sofia, Bulgaria  
[www.teletek-electronics.com](http://www.teletek-electronics.com)